

6500DC Dual Motor Wireless Controller Kits

READ ALL DIRECTIONS FIRST BEFORE PROCEEDING

NOTE: SEE THE QUICK PROGRAM INSTRUCTIONS BEFORE OPERATING THE FIRST TIME.
DO NOT REMOVE THE TRANSMITTER BATTERY

Please follow programming directions. Always disconnect power and ground cable when not in use. Do not mount the receiver near a vibrator or in an area where damage may occur. Use rubber grommets when mounting receiver box. Never jump start or put a battery booster on the vehicle without first disconnecting power to the receiver unit. Failure to do so will permanently damage the unit (no warranty for burnt boards whatsoever).

For use with 12 volt dc voltage only

How it Works:

The 6500DC Dual DC Motor Controller that provides RPM control for up to 2 single DC motors A up to 60AMP (Larger motor or conveyor or auger motor) and up to 40 amps to Motor B (smaller motor or spinner motor) The RPM control is done by providing the user 2 separate outputs, (3 speeds per motor low medium and full power) for each motor. The 6500DC incorporates an automatic shutdown to protect the motor and electronics.

- Automatic shut down if motor is locked up. Unit will shut down for approx.30-60 seconds before you can attempt a restart.
- Automatic shut off if the current draws do not drop below the rated amps after 5 to 7 seconds. Once again, the receiver will shut down for 30 to 60 seconds. You will need to investigate the problem as if you continue to override the control you will cause permanent damage to the receiver, motor or wiring.

Kit contains: note contents varies by kit ordered

- Receiver box with external antenna
- Junction wiring box for connections and optional switch box for added switched accessory
 - **NOTE THIS IS NOT NEEDED ON MOST RECEIVER HITCH SPREADER MODELS**
- Transmitter with rubber boot lanyard and label
- Breaker
- Short battery cable from positive battery cable to in lug breaker
- 24' vehicle Power Ground cable Black to Positive battery Red to out lug on breaker
- Relay and socket for optional vibrator or on off accessory see diagram
- 4 seal-tite pre lubed wiring connectors
- 8 anti-vibration washers for mounting receiver and junction box
- 2 dust caps
- 8 sheet metal screws #5x1
- 4 pre-lubed scotch locks
- 2 crimp on lugs
- Heat shrink
- 2 yellow heat shrink butt connectors
- 4 blue heat shrink butt connectors

Due to the numerous installation applications of this unit please follow all directions carefully or seek the help of someone that can.

Typical Wiring Connection Diagram

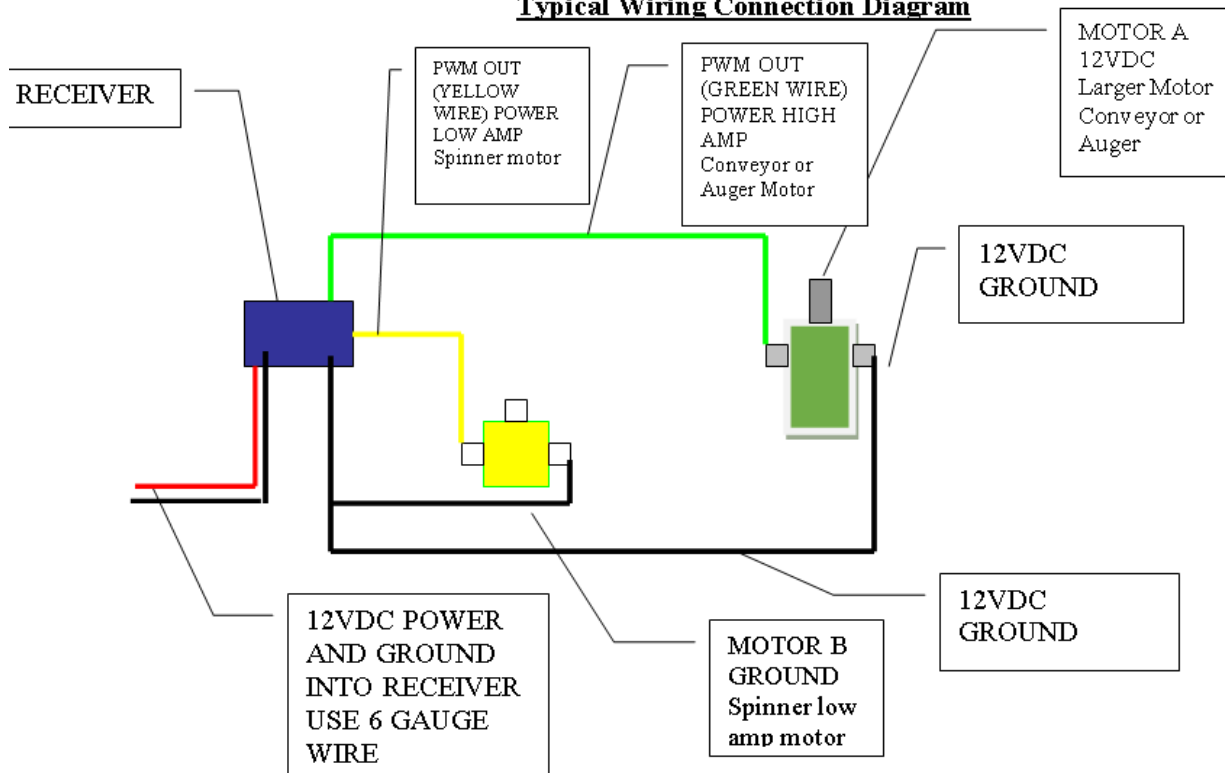

WIRING DIRECTIONS read carefully **DUAL motor instructions**

IMPORTANT you must cap off any wires not used failure to do this will cause damage to the unit.

1. Remove all current OEM Wiring, module boxes and switches from your salt spreader. You will not need any of it ever again.
2. Mount the wireless controller receiver and junction box on the driver's side of the salt spreader. Drill two holes on the junction box as needed in order to allow all connections to be made here. You may also install a manual switch to use with the auxiliary hot wire supplied if needed for a LED light or low amp device.
3. Use the provided purple seal-tite connectors for all connections at the wireless receiver.
4. Determine which motor controls your auger or conveyor, and which motor controls your spreader spinner.
5. Connect the "green" receiver wire to the hot side of the auger / conveyor motor.
6. Connect the "black" ground wire to the ground side of the auger motor.
7. Connect the "yellow" wire from receiver to the hot side of the spinner motor.
8. Connect the "black" ground wire from the receiver using the included connector with both spreader motor grounds. You will have (3) three ground wires total in this connector. If you are connecting the optional vibrator or auxiliary light, this ground will also be connected. Simply make a short black jumper wire and use another connector so all ground wires are "tied" together.
9. **NOTE: If your auger/conveyor or spinner motors are operating in reverse or start up automatically upon connection, you need to switch the power and ground wires so the spinner or auger motors run in the correct direction.**
10. Always test the functioning of your motors before closing the lids on the seal-tite connectors. We also suggest tightening all connections twice and adding dielectric grease before closing the covers on the seal-tite connections.

11. At the truck's battery, use the short power cord to go from the positive battery to the "in" lug of the provided circuit breaker
12. Connect the red positive of the 24' truck cable to the "out" lug of the breaker provided.
13. Connect the black ground of the 24' truck cable to the negative post of the truck's battery.
 - a. **NOTE: If you are separating the positive and negative wiring harness, be careful not to tear into the casing. Inspect and tape if needed.**
14. Secure the breaker under the hood of the truck and away from direct heat put off by the engine. Tape and protect all bare connections.
15. Run and secure the 24' quick disconnect power/ground cable to the desired location and away from direct heat/sharp objects.
16. Use the included dust covers on each end of the power cords to protect from corrosion.

IMPORTANT MAINTENANCE INFORMATION

- Use dielectric grease and clean connections on a regular basis
- Always unplug the power cords (positive/negative plug) when not in use. If you do not, this will enhance corrosion and cause your connections to fail.
- Do not use the wireless transmitter/key fob if frozen. Warm it up first before use or it may not operate properly.
- **Do not jump-start the vehicle with power connected to the spreader. This may burn out the unit and void warranty**

OPERATION: STANDARD 6500DC TRANSMITTER SHOWN

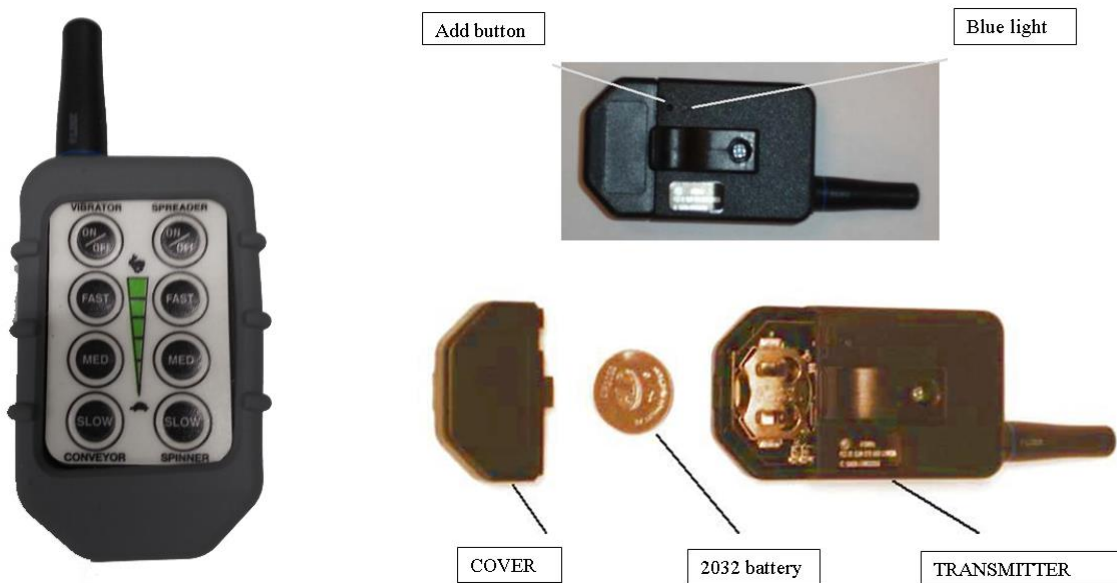

Shown above is a typical transmitter for wireless operation of a Dual 12VDC motor spreader. The button functions are as follows:

- Conveyor or motor 1: Slow, medium, fast. 1/3 increments between speeds.
- Spinner or motor 2: Slow, medium, fast. 1/3 increments between speeds.
- On/Off/Shuts down the receiver unit. Must be powered on again using the on/off button.
- Vibrator On/Off single switch can also be used for a LED light. Each single press of the button toggles on/off.

NOTE: It is recommended that when the DC motors are under high loads, that the control first be started at medium to high speed for the first 1 to 5 seconds of operation to avoid damage to the motor or controller as well as voiding the warranty. Always start your spinner motor first.

Programming Transmitter to Receiver: [Video link see online](#)

The following are step-by-step procedures for setting the unique address between the transmitter and receiver or adding extra transmitters to the receiver.

NOTE: You need to be next to the receiver and the receiver needs to have verified 12-volt power and ground connected, along with the receiver cover removed.

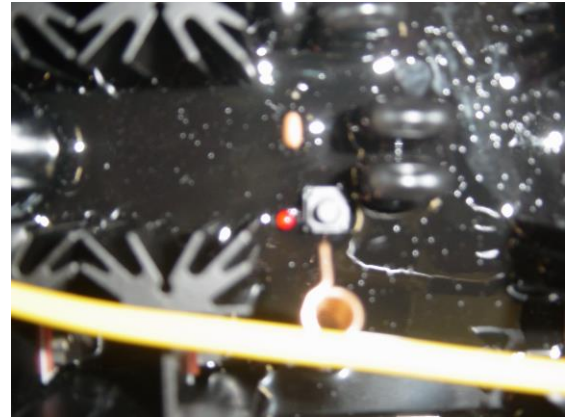

QUICK SETUP OF NEW UNIT- with power connected, remove the 4 cover screws from the receiver. Press the black button once (it should begin blinking red. Press and release any single button on the key fob the conveyor slow button once on the transmitter while the red light is still blinking. Now depress the black button in the receiver. The red light will stop flashing. You are now programmed.

The below directions are for a hard reset always use quick setup first.
With power connected to the receiver box

1. On the backside of the transmitter key fob, use a paperclip and **GENTLY** insert it in the hole next to the clear blue window. Once the button is pressed, a blue LED will begin to flash for 15 seconds.
2. While the blue light is flashing, Flip the keychain remote over and push and release each button individually.
3. Make sure the blue light stops blinking before proceeding.
4. Look inside the receiver box next to the small red LED light and press the black programming button. The red LED will begin to flash for 15 seconds.
 - a. NOTE: if the flash is dim, check your power and ground connections, clean connections, or repair.
5. While the red LED is flashing, Push and release any single button and release on the keychain remote
6. The red light will stop blinking. You have now completed the programming.
7. Re-install the cover on the receiver.

NOTE: The transmitter battery can last for years. Before removing the battery, you can check if it's still good by using the paperclip method outlined above. As long as the blue light starts flashing, the battery is fine. If you do attempt this, you will need to complete the rest of the programming process.

OPTIONAL – MEDIUM AND LARGE TRANSMITTER PROGRAMMING

1. Make sure the receiver and transmitter switches are powered on.
2. Remove cover from receiver
3. Press the black button. It will begin to blink.
4. While blinking, press the lower right button on the transmitter.
5. Press the black switch on the receiver and the light will go out.
6. You will now be programmed from the transmitter to the receiver.

TROUBLESHOOTING – READ THIS

- Do not change your transmitter battery unless you have followed proper troubleshooting for programming and reprogramming your transmitter to the receiver (see above).
- Always test your functions before loading your spreader so you can visually see and hear the different RPM functions.
- Make sure your discharge chutes are open and baffles adjusted to the material you are using.
- Keep the transmitter out of extreme cold or warm up before using.
- To verify power to the receiver, remove the cover and press the black button. If it blinks red, there is power to the unit.
- Keep power/ground connections clean and tight.
- Use dielectric grease and seal backside of all connections.
- Always disconnect power and ground cable when not in use.
- Always start spinner motor first before starting auger.
- Do not jumpstart your vehicle while the spreader is connected.
- If a timeout situation occurs on your spreader and continues to re-occur beyond two times, the operator needs to check for reasons why the spreader motors will not turn. Continually trying to start a jammed motor will cause damage to the receiver and the motor.
- Transmitters are a wearable part. We suggest having a spare in case you would lose it.

OPTIONAL VIBRATOR WIRING INSTRUCTIONS

Relay Instructions for vibrator or light connection. Follow these directions carefully. These directions should ONLY be followed with our relay socket.

A relay is basically a switching device. The difference is that it can handle more amperage than a typical switch allowing a typical switching device to power high amperage devices.

1. Connect 14 gauge red with black tracer to the blue wire on the relay socket or pin 30 of the relay
2. Connect one of the other 14 gauge red wires to the white wire of the relay socket or pin 85
3. You will be left with one extra red wire. This wire is hot and is used for switched additional accessories. This wire is not operated via wireless. You may install a switch in the junction box and operate low amp accessories, always use a relay if attempting to operate a higher amp device. If not using this wire it must be capped off.
4. Connect the yellow wire from the relay socket or pin 87 on the relay to the hot wire of the accessory. If connecting a vibrator it will not matter which of the two wires you choose on most vibrators, if there is a red and black wire red is power black is ground. If a black and white wire is coming out of the vibrator use black as power white as ground.
5. Connect the purple 18 gauge wire from the receiver harness to the black wire on the relay socket or pin 86 of the relay.

The middle pin 87A is not used, Pic below is looking at the relay with the pins facing you.

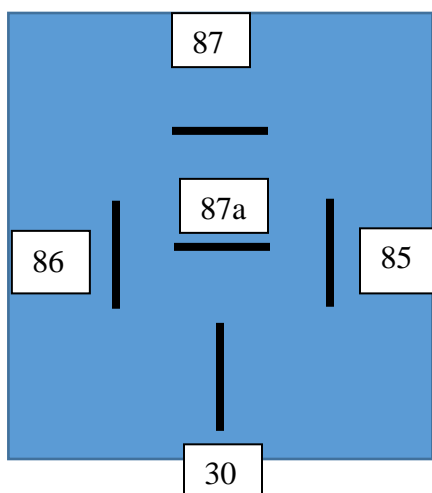

WARRANTY INFORMATION

- 1-year warranty on wireless receiver and wireless transmitter. See specific wireless warranty on the website for in depth details.
- Check online for any updated directions at <https://www.controlallwireless.com> or www.snowplowsplus.com
- User must maintain good, clean and properly connected connections in order for proper operation and to avoid damage to the receiver as well as possibly voiding the warranty. It is recommended that you use a battery disconnect when the unit is not in use, as continuous powered wiring will enhance corrosion of wiring. Always disconnect power when not in use!
- We have no control over the end user's method used to install our wireless controllers. For any warranty consideration, all units must be sent back for inspection and testing. Burnt boards or any modification of factory wires of any type means that failure to follow proper installation has occurred. With electronics, care needs to be taken and directions need to be followed in order to keep your warranty in tact. **All warranty claims will require pictures of the installation along with battery, fuse or breaker installation** before returning an item.no exceptions.